

## 2 MP HDCVI PTZ Kamera mit 32x optischem Zoom



### Highlights:

- 2 Megapixel STARVIS™ CMOS Bildsensor
- 150 m Nachtsicht
- H.265 Kompression
- PTZ Kamera 360° schwenkbar und 90° neigbar
- 32x optischer Zoom
- Max. 400°/s Geschwindigkeit
- Intelligente Video Analyse (IVS)

#### Kamera

Bildsensor	1/2,8" 2 Megapixel CMOS
Auflösung	1920 (H) × 1080 (V)
Scanning System	Progressiv
Min. Beleuchtungsstärke	0,005 Lux / F1.6
Signal-Rausch-Verhältnis	Mehr als 65 dB

#### Kamera-Eigenschaften

Nachtsicht	150 m
Gegenlichtkompensation	BLC / HLC / WDR (120 dB)
Weißabgleich	Auto / Manuell
Verstärkungsregelung	AGC
Rauschunterdrückung	2D / 3D

#### Objektiv

Brennweite	4,5 mm–144 mm
Max. Blende	F1.6–F4.0
Fokusteuerung	Auto / Manuell
Blickwinkel	H: 2,75°–60,14°, V: 1,54°–34,41°
Nahfokulentfernung	0,1–1,5 m

#### Sichtweite

Zoom (max. Brennweite)	Identifizierung: 198 m / Erkennung: 398 m Beobachtung: 785 m / Wahrnehmung: 1986 m
------------------------	---

#### Video

Auflösung	2 MP (1920 × 1080)
Bildrate	25 bps @ 2MP
Videoausgang	1 Kanal BNC HDCVI / CVBS / TVI / AHD
OSD Menü	Mehrsprachig
BLC Modus	BLC / HLC / WDR
WDR	120 dB

#### PTZ

Schwenk/Neigungsbereich	Schwenken: 0° – 360°; Neigen: -15° – 90°
Manuelle Geschwindigkeit	Schwenken: 300°/s; Neigen: 200°/s
Preset Speed	Schwenken: 400°/s; Neigen: 300°/s
Preset	300
PTZ Modus	5 Bewegungsmuster, 8 Touren, Auto Scan, Auto Schwenken
Geschwindigkeits Setup	Unterstützt
Leerlauf	Voreinstellung / Schwenken / Scan / Tour / Pattern

#### Anschlüsse

RS-485	1
Alarm	2 In / 1 Out
Audio	1 In

#### Allgemein

Netzteil	24 V DC / 2,5 A
Energieverbrauch	< 22 W
Betriebstemperatur min.	-40 °C
Betriebstemperatur max.	+70 °C
IP Schutzklasse	IP66
IK Schutzart	/
Maße	Φ 186 mm × 310 mm
Gewicht	3,9 kg

## Maße

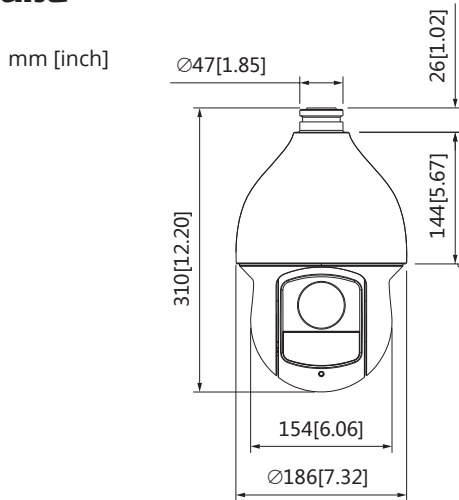

## Zubehör (enthalten)



Wandhalterung

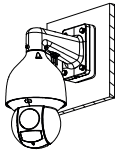

Netzteil

## Zubehör (optional) / Installationsbeispiele



NH-AD1



NH-AD2



Kombination:  
NH-AD2  
+NH-DH1



NH-PTB4

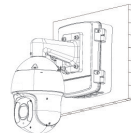

Kombination:  
Wandhalter  
+NH-PTB4



NH-PTB2



NH-DH1



Kombination:  
NH-DH1  
+NH-AD2



NH-DHV2



NH-DHV3



NH-AB8



NH-MH1

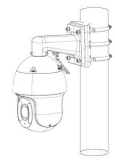

Kombination:  
Wandhalter  
+NH-MH1



NH-FH1

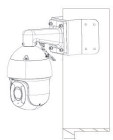

Kombination:  
Wandhalter  
+NH-FH1



NH-BST1



Kombination:  
NH-BST1  
+NH-AD2



NH-BST2



## Lieferumfang

Kamera, Netzteil, Wandhalterung, Bedienungsanleitung, Montagezubehör

Technische Änderungen und Irrtümer vorbehalten. Abbildungen können abweichen.